

# Smalley 360/5 Mk2



# 360/5 Mk 2

The Smalley 360/5 Mk. 2 must be the most versatile excavator on the market today, offering increased output with very considerable savings on capital and running costs. It can dig at the rate of 15 cubic yards per hour, on approximately a gallon of diesel fuel a day. Simply towed to the site by Land-Rover or van, the



Easily towed to site

Smalley 360/5 takes just 3 minutes to set up and get to work. Having no prime-mover, it simply 'walks' into position.

By operating the jib and dipper, it takes strides of up to 8 ft., forwards, backwards and sideways, at about 2½ m.p.h. Steering is carried out by operation of the slewing control whilst the excavator is on its wheels

and the front legs clear of the ground.

When set to work, the 360/5 will excavate anything from complex house footings in 4½ hours, to digging really sheer sided cess-pits up to 8 ft. deep.

Ground conditions present no problem to the Smalley 360/5. With its unique action,



Detachable drawbar for towing



Working in heavy clay conditions



Skimming with 42" backfill bucket



New cab design



Complex house footings can be dug quickly, safely and neatly

it can work effectively on gravel or deep mud, tip-toe over soft earth, or exert extreme pressure on rocky terrain. Its capability must be seen to be believed—vertical trenching on a 20° incline, site clearing, loading into high-sided tippers, cable and drainage trenching, and post holing are typical everyday situations.

A new feature, unique to the 360/5, is the ability to switch the jib (in less than one minute) to an off-set position. This enables the excavator to operate safely and neatly in confined conditions (within 6 inches of walls), where its competitors could never go. The Smalley 360/5 just walks it.



Ease of offset adjustment to jib

With a re-designed cab, the Mk. 2 gives much improved comfort and warmth to the driver, with complete all-round visibility. A complete range of quick-change accessories enables the Smalley 360/5 Mk. 2 to tackle virtually any job, quickly, efficiently and economically all the year round.



Bucket adjustment allows for square-hole digging to 8ft. depth



With jib in offset position, the 360/5 can work very close to uprights



Off-loading into high-sided truck



Vertical trench digging on a 20° bank using self-levelling adjustable stabilisers

# 360/5 Mk 2

## Specification

### Engine:

Lister SR1 Air-cooled diesel 7.5 hp at 2000 rpm with 2½ gallon (11.3 litres) fuel tank.

### Hydraulic Pump:

Dowty Pump Model 3000 Gear-type direct coupled to engine; displacement 4.5 gpm (20 litre per min) at 2150 psi (152 kg cm<sup>2</sup>).

### Hydraulic Oil:

Capacity 9 gallons (41 litres) cooled by distribution around the framework. Full flow 'Tell-Tale' filtration system.

### Hoses:

All twin-braid to BSS 3640.

### Hydraulic Rams:

All 2" (51 mm) bore with 1½" (35 mm) dia. piston rod. Micro-finish to bore and heavy chrome plated rods.

### Comfort Cab:

Full view, with Triplex safety glass all round, sliding windows, folding door, sound proofed. Complete with heating and full ventilation when required.

### Slew:

360 degree continuous slewing Hydraulic motor provides instant starting torque. Speed of slew 7 rpm. Safety valves provided for full protection when stopping from full speed. Super-structure mounted on a Ball-Bearing Slewing Ring.

### Wheels & Brakes:

Single bolt hubs, 24" x 7.50 (610 mm x 7.50) 6-ply tyres, over-run type 8" (200 mm) brakes, draw-bar connection eye-type or socket.

### Weight:

Complete with 24" (610 mm) Bucket, 28 cwt (1422 kilos)

### Width:

5' 7" min. (1.7 m)

### Digging & Loading Data:

Max. reach with standard jib

12' 9" (3.90 m)

Max. digging depth

8' 0" (2.40 m)

Max. overloading height

9' 0" (2.75 m)

### Features:

Fully continuous 360° slewing & left and right hand off-set jib adjustment enabling the machine to dig within 6" (150 mm) of a wall with an 18" (460 mm) bucket.

### Controls:

All controls conveniently placed for easy operation

## Optional Extras

### Choice of Buckets:

HD Excavating buckets 6"-24" (150-610 mm)

Backfill and ditching buckets 30"-60" (750-1500 mm)

Hydraulic capstan or winch, both fitted with torque limiting valves

Hydraulic Concrete/Tarmac breaker

Adaptor for face-shovel application

Electric starting & lighting equipment

Special feet for pavement work Ripper tooth

Tapered bucket to order

Steep hill excavation unit available

A larger capacity version, the 360/15, is available with all the unique Smalley principles and both models can be demonstrated anywhere in the UK.

**Smalley Excavators are Guaranteed for Six Months**



Engine layout permits good access for maintenance



Controls layout in Mk. 2 Cab, with everything to hand.



There is a wide selection of optional buckets and accessories



Easy access to fuel tank for filling

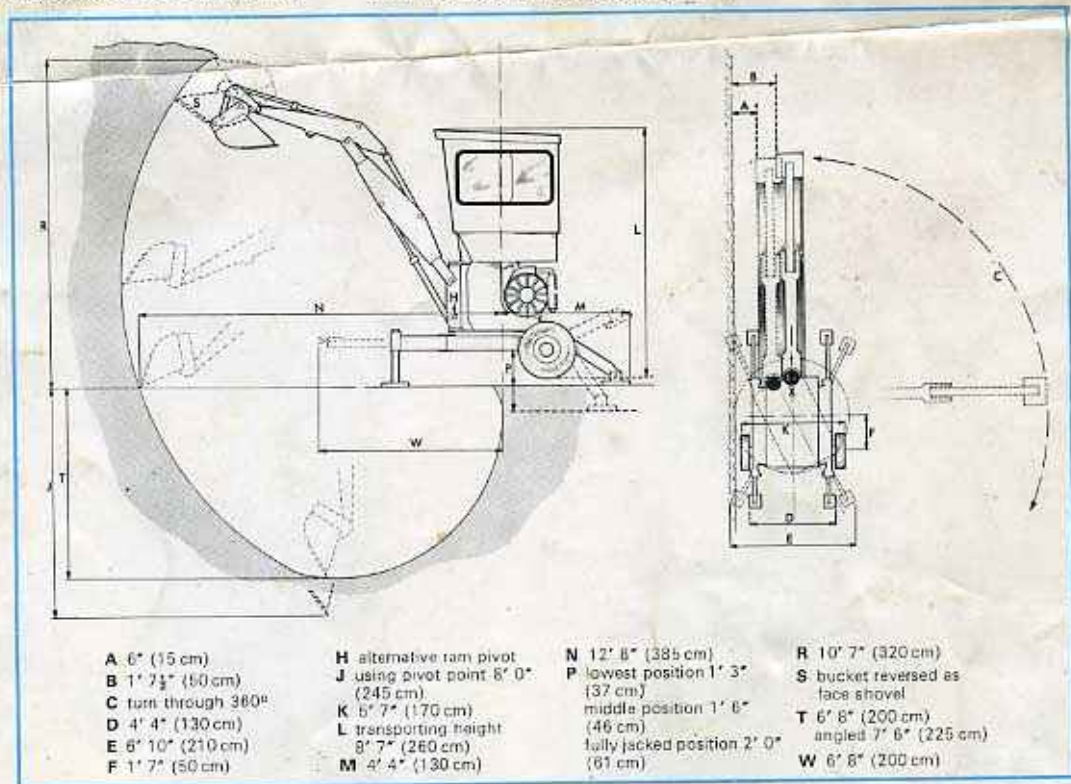

Over 500 Smalley 360/5 excavators have been manufactured and are currently earning high profits for builders and contractors throughout Britain. A considerable number have been exported all over the world, and are operating successfully in tropical and arctic conditions.

To arrange a demonstration, just contact

**Richard Smalley (Engineering) Ltd.**  
Osournby, Sleaford, Lincolnshire, England  
Tel. Culverthorpe 206 and 335. Telex 37247

*The policy of the company is one of continuous improvement and it reserves the right to change specifications and prices without notice.*

