

EUROMACH

**OUT DIGS
THEM ALL**

EURO



Front and rear fully adjustable
gives rigid and



Lombardini's proven 12
maximum efficiency

Hydraulic system 32 litre
with auto compensated 5
with built-in anti-shock

Offers a loading height of
depth of 2.



Lift off covers for easy
hydraulic

All machines include ground
stand

Wide range of bucket
applications easily adapted
hand-held equipment
breakers, hole borers

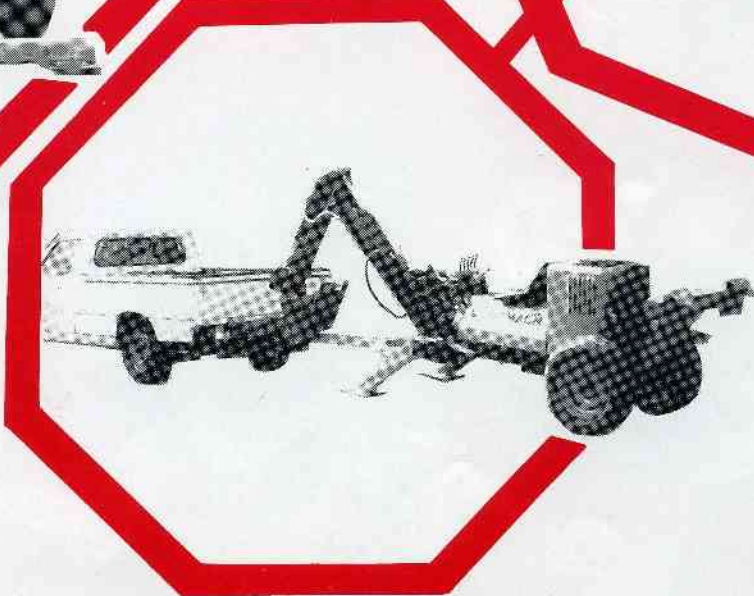

EURO

MACH

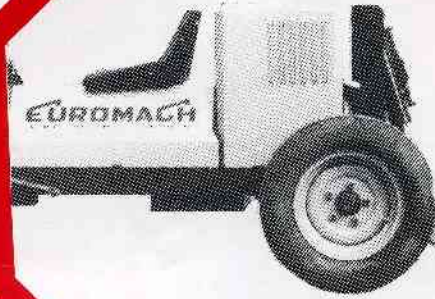

Stable stabilising legs
level digging.

HP diesel engine gives
7 at minimum cost.

geared hydraulic pump
lever distributor valve
and drop relief valve.

f 3.2 metres and digging
4 metres.

access to engine and
system.

ick release tow bar as
lard.

s available to suit all
ted to operate hydraulic
including:- concrete
s, and cutting tools.

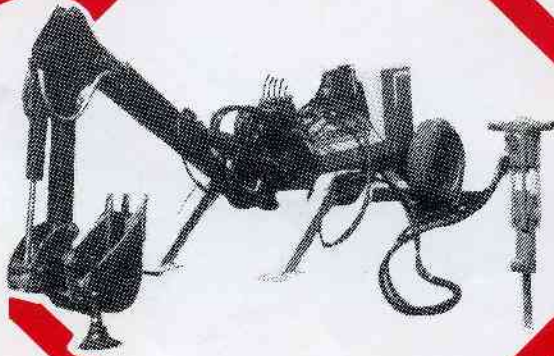
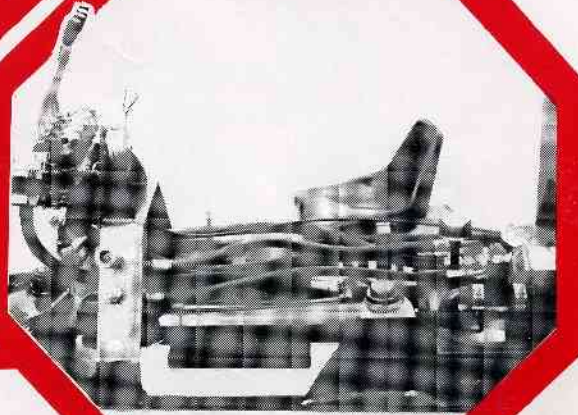

MACH

SPECIFICATIONS

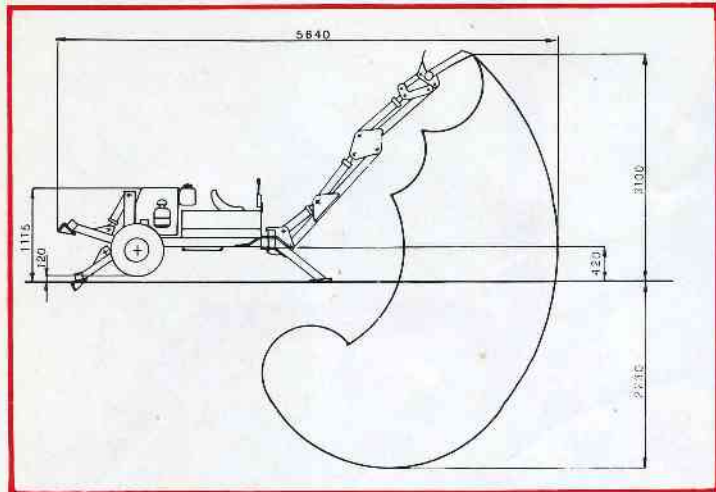

Technical

- A. Weight in working order** 800 Kg
- B. Ground pressure** 0.27 Kg/cm
- C. Steel frames with welded profiles**
- D. All wear parts fitted with tempered steel bushes**
- E. All buckets are reversible**

Hydraulics

- A. Pump capacity** 32 Lts
- B. Oil capacity** 42 Lts
- C. Working pressure** 220 Bar
- D. 5 lever grouped distributor valve**
- E. Built-in anti-drop safety valve**

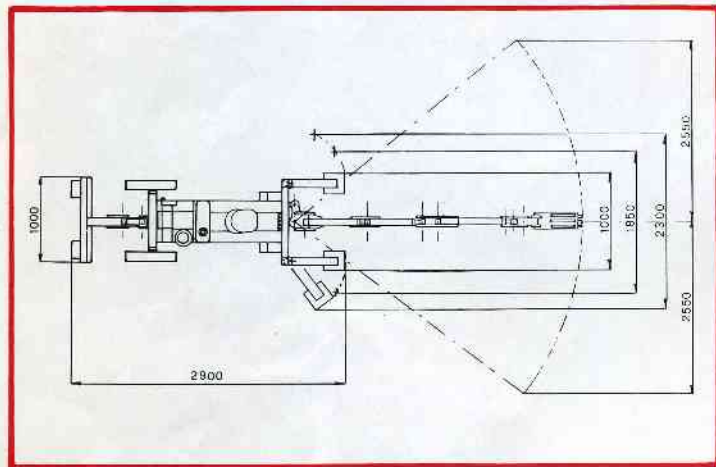

Engine

- A. 4-stroke Lombardini diesel**
- B. Fuel capacity** 4.9 Lts
- C. Cylinder capacity** 7.38 cm
- D. Maximum output** Kw HP/12/163
- E. Calibration output** 12 HP
- F. Self lubricating injection system**

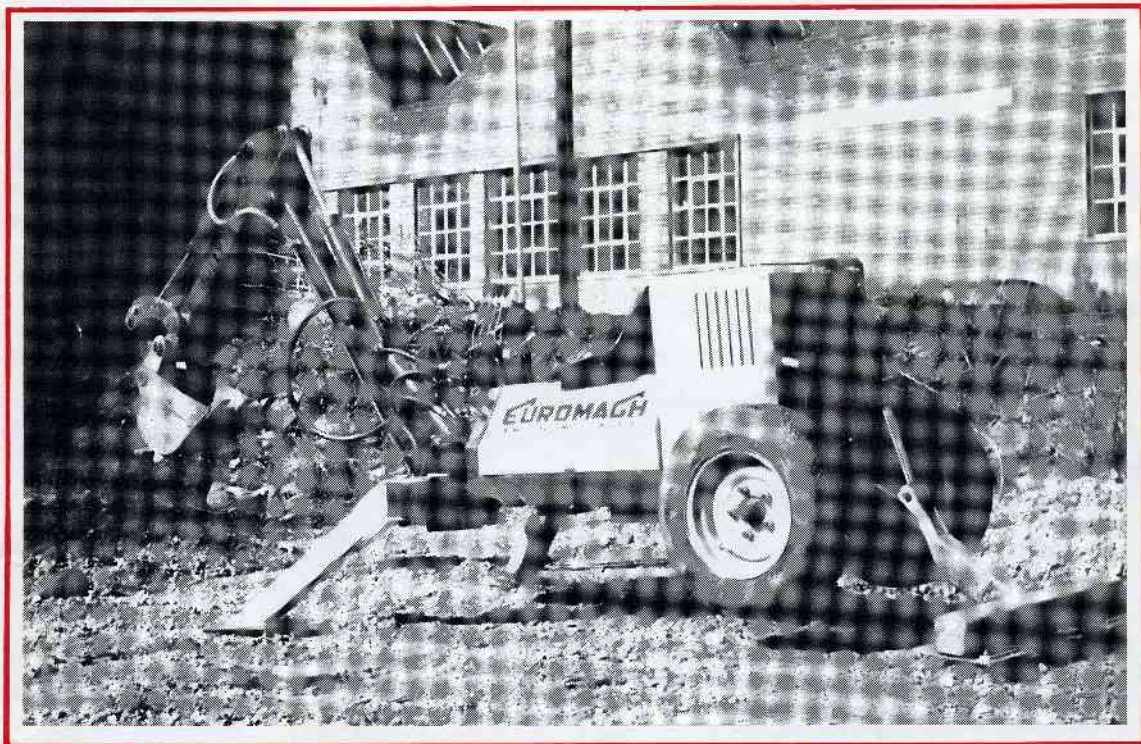

Your friendly agent is:-

**THE MOST POWERFUL & VERSATILE MICRO
EXCAVATOR ON THE WORLD MARKET !**

PLANT & HYDRAULICS (UK) LTD.
231 BRADFORD ROAD
BATLEY
LEEDS WF17 6JL
TEL. 0924-455090
0924-454621